

AUTOMATION BALL VALVES
WITH EQUAL PERCENTAGE CHARACTERISTIC

2010

NEW

2 WAY



ENOLGAS



SWIFT•O•MATIC® 2-WAY



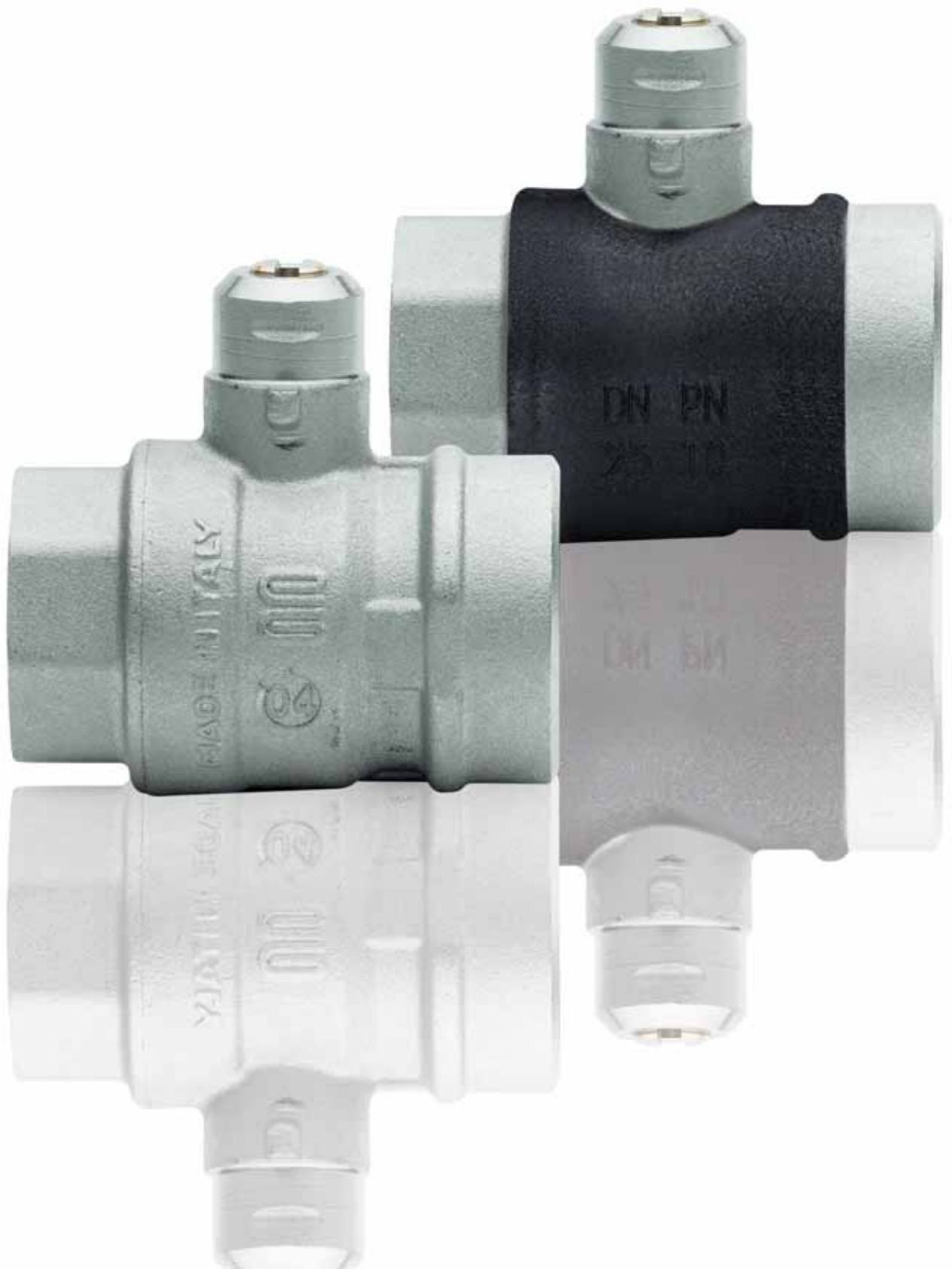



2-way valve quick mounting

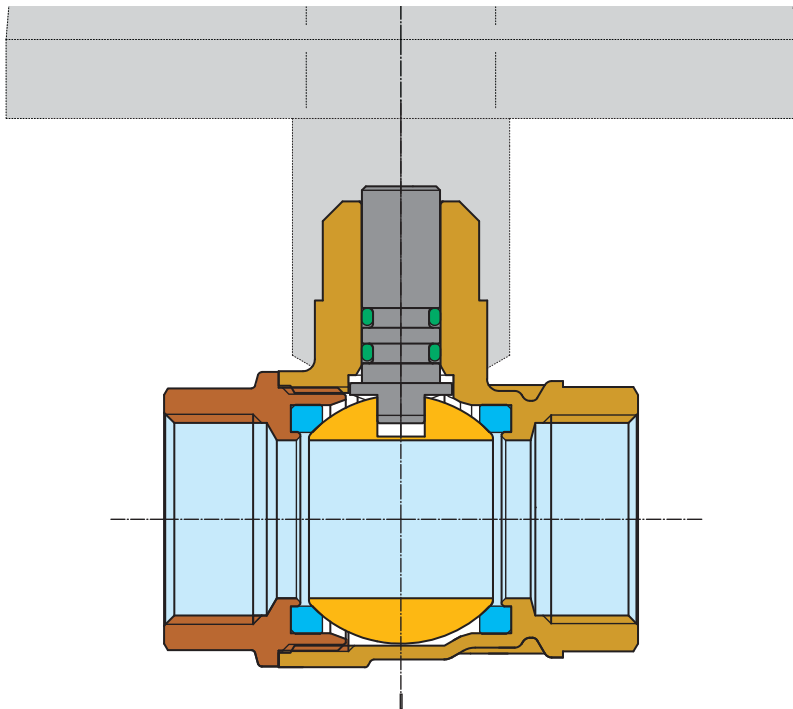

SWIFT•O•MATIC® QM

Quick mounting full bore ball valve



BODY 1	
CW 617 N UNI EN 12165	
END ADAPTER 2	
CW 617 N UNI EN 12165	
BALL 3	
CW 614 N UNI EN 12164	
BALL GASKETS 4	
P.T.F.E.	
STEM 5	
CW 614 N UNI EN 12164	
THRUST WASHER 6	
P.T.F.E.	
STEM GASKET 7	
2 ELASTOMER O-RINGS	

TECHNICAL, DYNAMIC AND STRUCTURAL CHARACTERISTICS

CHARACTERISTICS AND NORMS

SWIFT•O•MATIC QUICK MOUNTING valves are made of brass, robust and specially designed to be easily and quickly automated with the actuators.

Full bore.

Brass: UNI EN 12165 CW 614 / CW 617 N

Threaded connections: NPT - BSPT - ISO 228

PED 97/23/CE - MODULE H

LIMITS OF USE

Temperature: -4F (-20°C) + 266F (130°C) (valve)

Temperature: -4F (-20°C) + 176F (80°C) (actuator)

MAIN USES

Hot, cold water and air

Hydrocarbons in general

Non-aggressive fluids

ADVANTAGES AND COMPETITIVENESS

The mechanical characteristics of **SWIFT•O•MATIC QUICK MOUNTING** provide the motorized valve with considerable advantages.

The quick and easy connection between the **SWIFT•O•MATIC QUICK MOUNTING** valve and the actuator is extremely stable.

The reduced operating torque allows a substantial reduction in the choice of the electrical or pneumatic drives.

COATED OPTIONS



POLYMER PROPERTIES	UNITS	GLOBAL	TEST METHOD
DENSITY	Kg/m ³	500	ISO 845
TENSILE STRENGTH	Kg/cm ²	45	ISO 37
ELONGATION AT BREAK	%	100	ISO 37
TEAR STRENGTH	N/m	11	ISO 34
HARDNESS AT 23°C	Shore A	65-70	ISO 868
COMPRESSION SET (50%)	%	10	ISO 1855
C.L.D. (40%)	Kpa		ISO 3386
TEMPERATURE LIMITS	°C	-20 +110	-

1. Tensile and Elongation core properties were tested also according to ISO 1798 Test Method

The coated valves has been designed for chilled water applications, easier installation and coating of the pipeline. So the most complicated part, between the valve and the actuator, is already coated with Semirigid Integral Skin foams with model density of 400-600 kg/m³ and a skin hardness of 60-77 Shore A.

NOTE: To require this valve, please put a "P" instead of "N" in the articles number.



Art. S.3041
SWIFT•O•MATIC QM

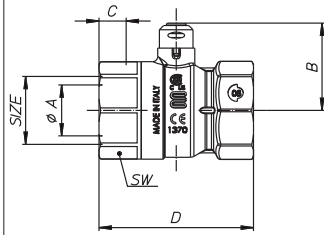

Size	1/2"	3/4"	1"	1 1/4"	1 1/2"	2"
øA bore	15	20	25	32	32	40
B mm	37	41	45	50	50	57,5
C mm	7,2	11	12,5	13,5	15,5	17,5
D mm	50	58,5	77	82	90	105
SW mm	26	31	38	47	54	66

Ball valve, full bore, female/female, with quick mounting connection for actuator, nickel-plated.

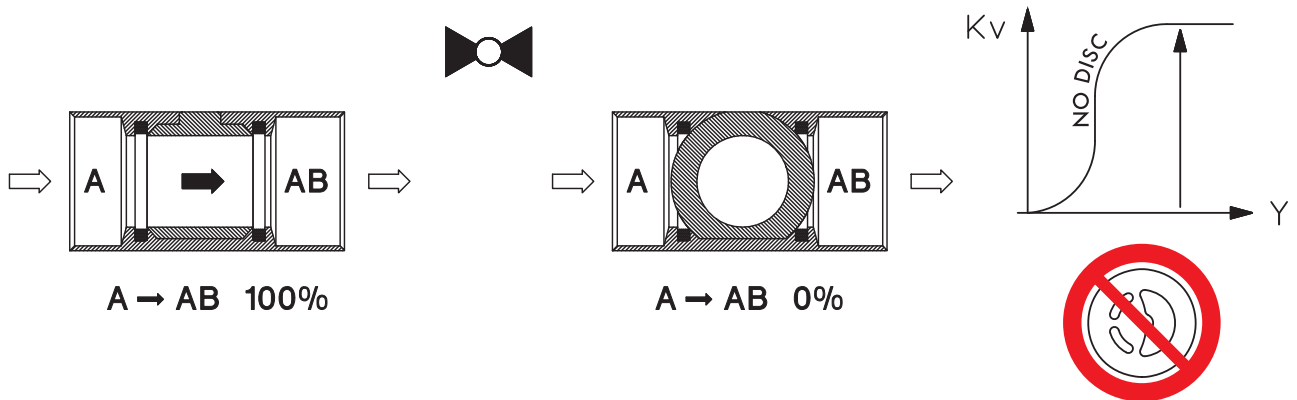

BALL VALVE FOR 2-POSITION CONTROL ON-OFF FULL BORE WITHOUT DISC

Size	1/2"	3/4"	1"	1" 1/4	1" 1/2	2"
DN (mm)	15	20	25	32	40	50
Kvs (m ³ /h)	17	41	70	121	121	200
Article	S3041N04	S3041N05	S3041N06	S3041N07	S3041N08	S3041N09

Pressure/temperature diagram
(test carried out with water)

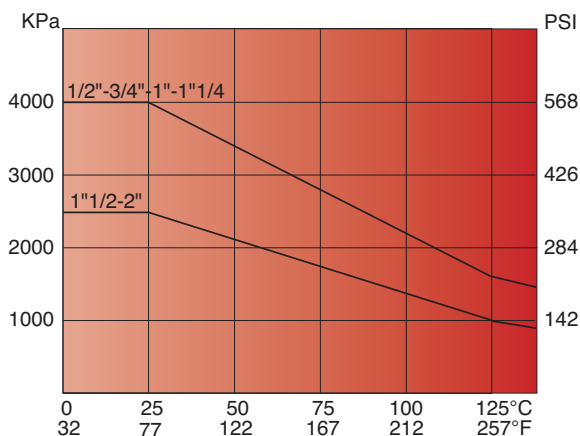

Loss of head diagram
(for water applications)

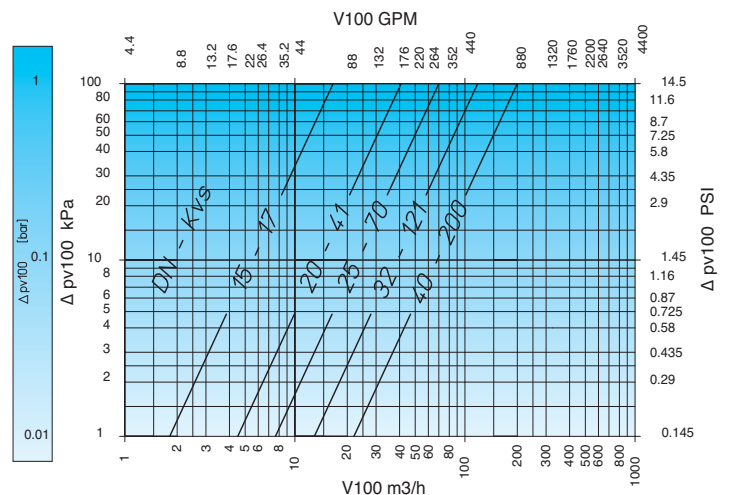



Art. S.3041
SWIFT•O•MATIC QM

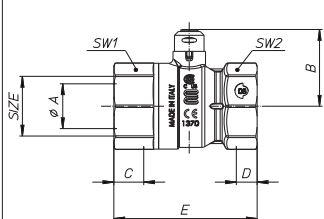

Ball valve, full bore, female/female, with quick mounting connection for actuator, nickel-plated, with optimizer disc.

Size	½"	¾"	1"	1¼"	1½"	2"
ØA bore	15	20	25	32	32	40
B mm	37	41	45	50	50	57,5
C mm	15	16,3	19,1	21,4	21,4	25,7
D mm	7,2	11	12,5	13,5	15,5	17,5
E mm	56	64,5	77	90,5	95	112,5
SW1 mm	26	31	38	47	54	66
SW2 mm	26	30	38	47	54	65

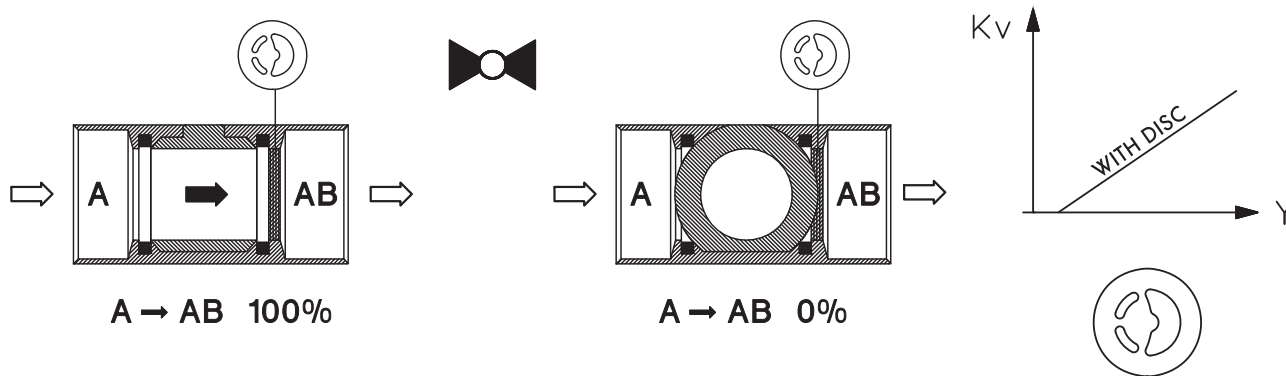

BALL VALVE FOR MODULATING CONTROL WITH DISC

Size	1/2"	3/4"	1"	1 1/4"	1 1/2"	2"
DN (mm)	15	20	25	32	40	50
Kvs (m ³ /h)	3	6,7	9	16	20,4	31
Article	S3041N35 + S1661L04 + S1665P04	S3041N37 + S1661L05 + S1667P05	S3041N40 + S1661L06 + S1668P06	S3041N42 + S1661L07 + S1669P07	S3041N44 + S1661L08 + S1671P08	S3041N46 + S1661L09 + S1672P09

Operation

The parabolic shape of the flow optimizer orifice (figure 1) provides a slowly opening valve. Equal movements of the valve stem, at any point of the flow range, change the existing flow an equal percentage regardless of existing flow. The ball valve equal percentage flow characteristic (figure 2) mirrors the flow characteristic of a coil, resulting in linear heat transfer.

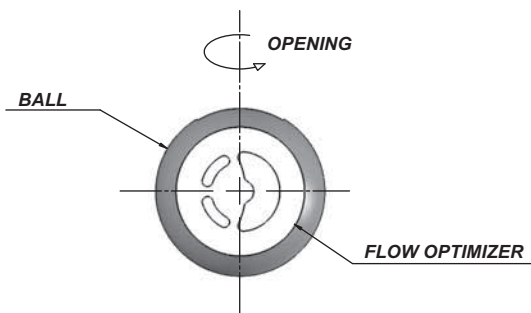

Fig. 1 Ball Valve Flow Optimizer

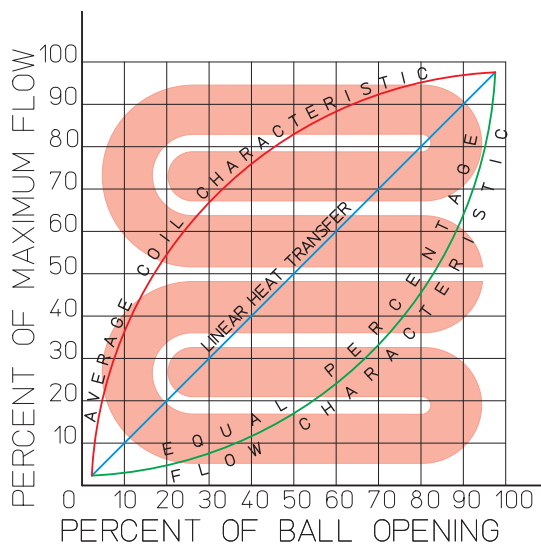
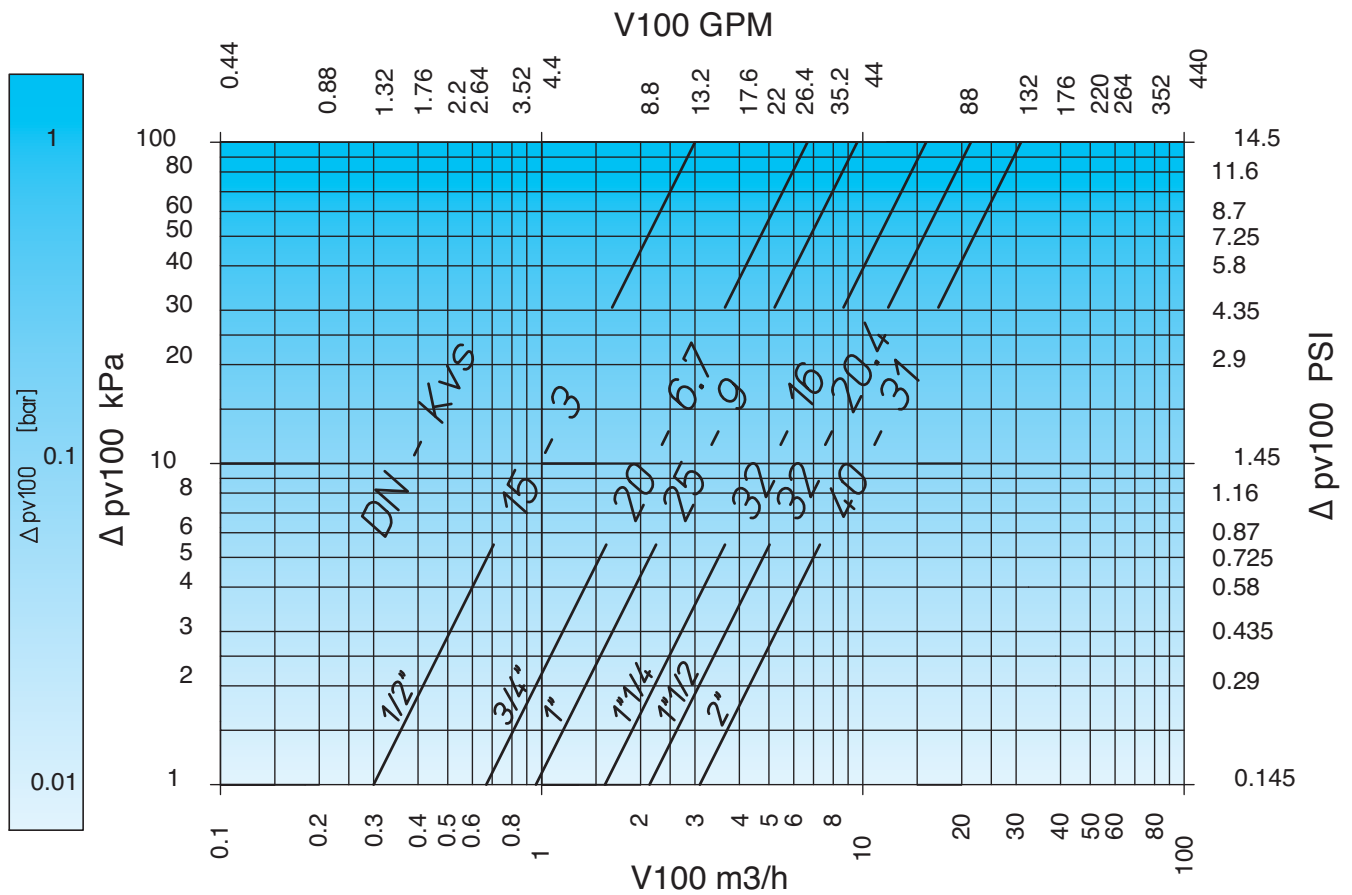

Fig. 2 Ball Valve Equal Percentage Flow Control



Loss of head diagram with optimizer disc



- Size from DN 15.....up to DN 50 mm (1/2".....2")
- Kvs 3.....to 292 m³/h
- Can be easily equipped with R2813.....S2815.....S2818.....S2912..... for 2-Way valve
- Manual assembly between valve and actuator quick mounting
- Suitable for small or medium size-sized heating, ventilating and air conditioning plants as a control or safety shut off valve
- Cooling water
- Chilled water
- Low temperature hot water
- Water with anti-freeze
- Range = -20 to + 130°C



2-WAY

TABLE 1

VALVE PRODUCT NUMBER	FLOW OPTIMIZER DISC	SIZE	DN (mm)	TORQUE (Nm)	Kvs (m ³ /h)
S3041N35 + S1661L04 + S1665P04	*	1/2"	15	2,7	3
S3041N04	17				
S3041N37 + S1661L05 + S1667P05	*	3/4"	20	3,7	6,7
S3041N05	41				
S3041N40 + S1661L06 + S1668P06	*	1"	25	5,6	9
S3041N06	70				
S3041N42 + S1661L07 + S1669P07	*	1" 1/4	32	6,6	16
S3041N07	121				
S3041N44 + S1661L08 + S1671P08	*	1" 1/2	40	8	20,4
S3041N08	121				
S3041N46 + S1661L09 + S1672P09	*	2"	50	9,5	31
S3041N09	200				

2-WAY ACTUATOR

TABLE 2

VALVE PRODUCT NUMBER	230V 3 POINT CONNECTION NO MICRO RED COLOUR	230V 3 POINT CONNECTION ON-OFF	24V 3 POINT CONNECTION ON-OFF	230V 2 POINT CONNECTION ON-OFF	24V 2 POINT CONNECTION ON-OFF	24 V 0-10 VDC MODULATING	230 V 0-10 VDC MODULATING
S3041N35 + S1661L04 + S1665P04	R2813P00	S2815P00	S2816P00	S2817P00	S2818P00	S2912P00	AV. ON RQST
S3041N04	R2813P00	S2815P00	S2816P00	S2817P00	S2818P00	S2912P00	AV. ON RQST
S3041N37 + S1661L05 + S1667P05	R2813P00	S2815P00	S2816P00	S2817P00	S2818P00	S2912P00	AV. ON RQST
S3041N05	R2813P00	S2815P00	S2816P00	S2817P00	S2818P00	S2912P00	AV. ON RQST
S3041N40 + S1661L06 + S1668P06	R2813P00	S2815P00	S2816P00	S2817P00	S2818P00	S2912P00	AV. ON RQST
S3041N06	R2813P00	S2815P00	S2816P00	S2817P00	S2818P00	S2912P00	AV. ON RQST
S3041N42 + S1661L07 + S1669P07	R2813P00	S2815P00	S2816P00	S2817P00	S2818P00	S2912P00	AV. ON RQST
S3041N07	R2813P00	S2815P00	S2816P00	S2817P00	S2818P00	S2912P00	AV. ON RQST
S3041N44 + S1661L08 + S1671P08	R2813P00	S2815P00	S2816P00	S2817P00	S2818P00	S2912P00	AV. ON RQST
S3041N08	R2813P00	S2815P00	S2816P00	S2817P00	S2818P00	S2912P00	AV. ON RQST
S3041N46 + S1661L09 + S1672P09	R2813P00	S2815P00	S2816P00	S2817P00	S2818P00	S2912P00	AV. ON RQST
S3041N09	S3041N07	S2815P00	S2816P00	S2817P00	S2818P00	S2912P00	AV. ON RQST

Note: Valve marked with an asterisk (*) have a flow optimizer disc for modulating applications.

Note: For coated valves specify the last letter with P instead of N or L on the valve product number.

Example: S1070P36.



2-WAY ON-OFF

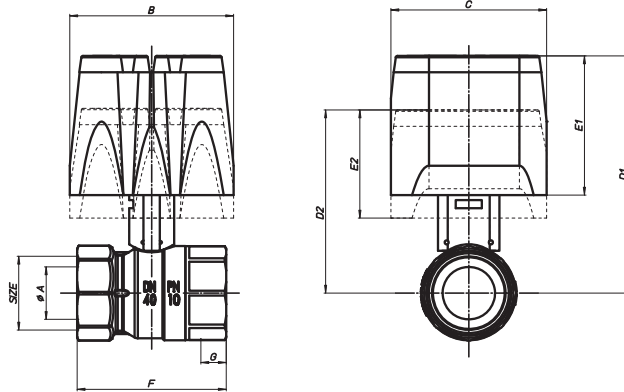

Size			½"	¾"	1"	1¼"	1½"	2"
øA bore			15	20	25	32	32	40
B mm			100	100	100	100	100	100
C mm			73	73	73	73	73	73
D1 mm			122	126	130	135	135	142
E1 mm			76	76	76	76	76	76
D2 mm			110	114	118	123	123	130
E2 mm			66	66	66	66	66	66
F mm			50	58,5	71	82	90	105
G mm			7,2	11	12,5	13,5	15,5	17,5

2-WAY MODULATING

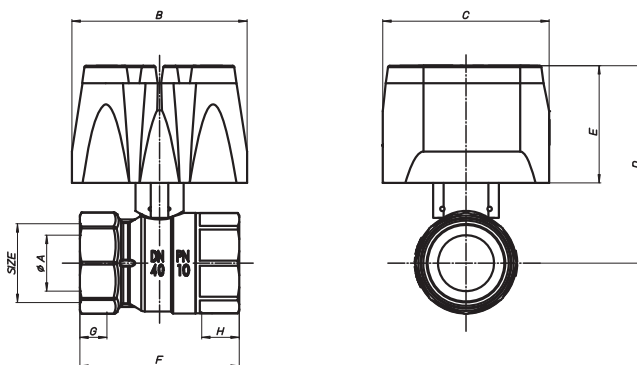

Size			½"	¾"	1"	1¼"	1½"	2"
øA bore			15	20	25	32	32	40
B mm			100	100	100	100	100	100
C mm			73	73	73	73	73	73
D mm			110	114	118	123	123	130
E mm			66	66	66	66	66	66
F mm			57	64,5	77	90,5	95	112,5
G mm			7,2	11	12,5	13,5	15,5	17,5
H mm			15	16,3	19,1	21,4	21,4	25,7

3-WAY ON-OFF and MODULATING

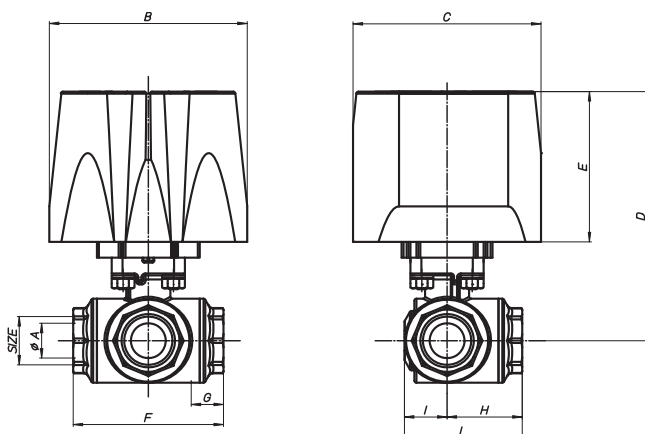

Size	¼"	¾"	½"	¾"	1"	1½"	1¾"	2"
øA bore	8	10	14,1	17,6	25	-	-	-
B mm	100	100	100	100	100	-	-	-
C mm	73	73	73	73	73	-	-	-
D mm	122	122	122	126	130	-	-	-
E mm	66	66	66	66	66	-	-	-
F mm	64,5	64,5	64,5	76	97	-	-	-
G mm	15	15	15	16,3	19,1	-	-	-
H mm	32,5	32,5	32,5	38	48,5	-	-	-
I mm	17	17	17	21,5	26	-	-	-
L mm	49,5	49,5	49,5	59,5	74,5	-	-	-

SWIFT•O•MATIC® QM

Assembly 2-way

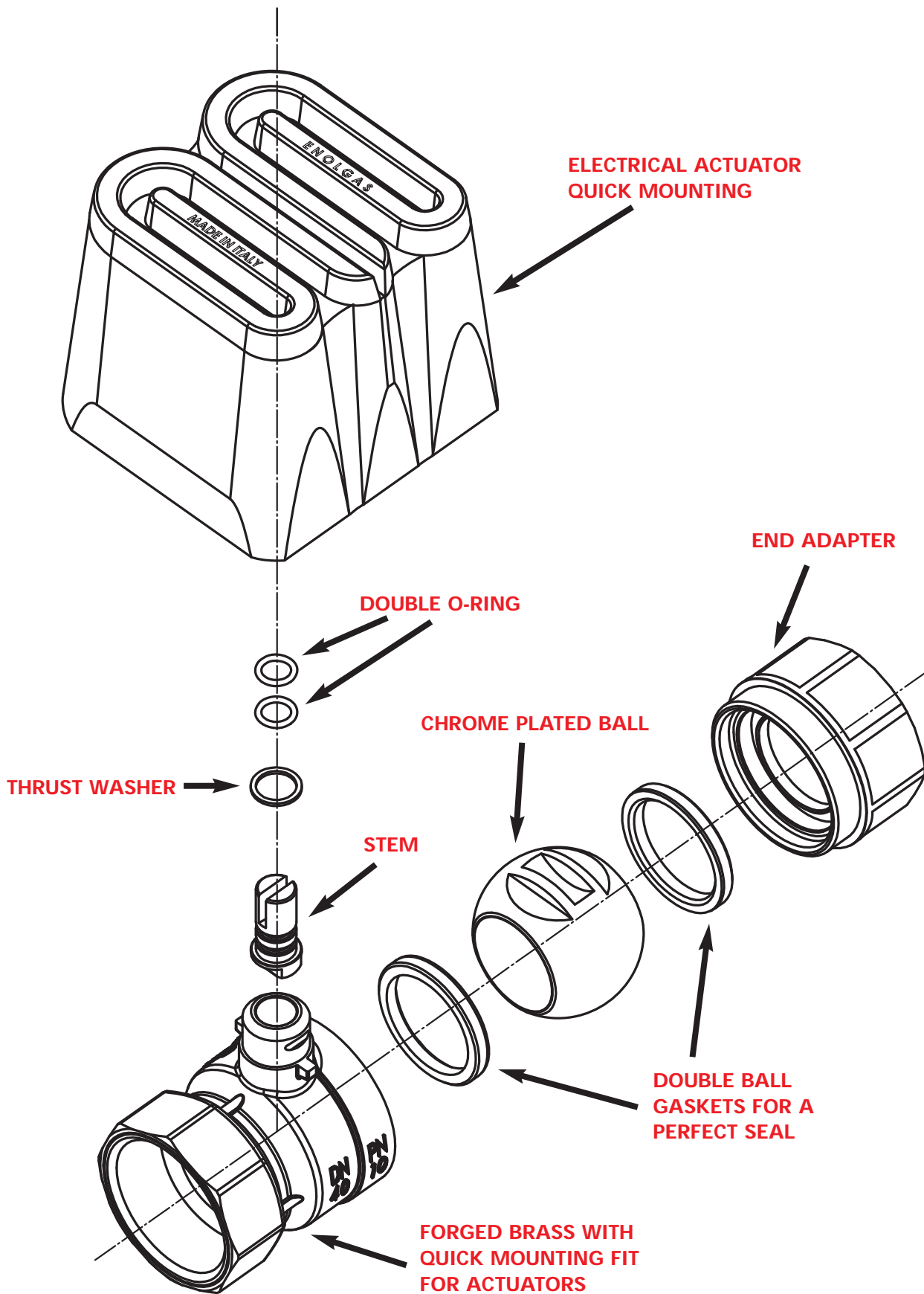

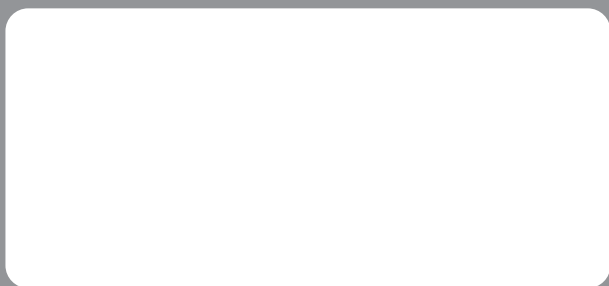

ENOLGAS BONOMI S.p.A. • via Europa 227 • 25062 Concesio (Bs) • Italy
tel. 030 2184311 • fax 030 2184333 • www.enolgas.it • enolgas@enolgas.it